

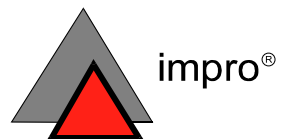

# ImproX VT Infrared Transmitter

## INSTALLATION MANUAL

**MODEL: IVT-900-0-1-GB-XX**



## IMPORTANT NOTICE

Although all efforts have been made to make this manual as accurate as possible, Impro Technologies (Pty) Ltd does NOT accept any liability for errors or omissions. The data contained in this manual supersedes any other information published on the product. We further reserve the right to amend or improve the equipment and manual without notice.

## GUARANTEE / WARRANTY

Impro Technologies (Pty) Ltd warrants that the Products furnished under this agreement will be free from material defects in material and workmanship for a period of three years from the date of shipment. The Customer shall provide notice to Impro Technologies (Pty) Ltd of each such defect within one week after the Customer's discovery of such defect. The sole obligation and liability of Impro Technologies (Pty) Ltd under this warranty shall be to repair or replace at Impro's sole discretion, but without cost to the Customer, the product or part which is so defective and as to which such notice is given.

Upon request by Impro Technologies (Pty) Ltd, the product or part claimed to be defective shall immediately be returned at the Customer's expense to Impro Technologies (Pty) Ltd. Replaced or repaired products or parts will be shipped to the Customer at the expense of Impro Technologies (Pty) Ltd.

There shall be no warranty or liability for any products or parts which have been subject to misuse, accident, negligence, failure of electric power or modification by the Customer without Impro Technologies (Pty) Ltd written approval. Final determination of warranty eligibility shall be made by Impro Technologies (Pty) Ltd. If a warranty claim is considered invalid for any reason, the Customer will be charged for services performed and expenses incurred by Impro Technologies (Pty) Ltd in handling and shipping the returned item.

As to replacement parts supplied or repairs made during the original warranty period, the warranty period of the replacement or repaired part shall terminate with the termination of the warranty period with respect to the original product or part.

As Impro Technologies (Pty) Ltd has no control over where the product is used, or how it is installed, no liability for ANY consequential damages can be accepted, whether due to malfunction, design, deficiency, implementation or any cause whatsoever.

Impro Technologies does not guarantee interfacing compatibility of any of its equipment with any third-party equipment, regardless of any standards which may be applicable. Connecting third-party equipment to any Impro equipment may compromise the functionality of the Impro equipment and render it inoperative.

THE FOREGOING WARRANTY CONSTITUTES IMPRO TECHNOLOGIES (PTY) LTD SOLE LIABILITY AND THE CUSTOMERS SOLE REMEDY WITH RESPECT TO THE PRODUCTS AND IS IN LIEU OF ALL OTHER WARRANTIES, LIABILITIES AND REMEDIES EXCEPT AS THUS PROVIDED, IMPRO TECHNOLOGIES (PTY) LTD DISCLAIMS ALL WARRANTIES, EXPRESS OR IMPLIED, INCLUDING ANY WARRANTY OF MERCHANTABILITY OR FITNESS FOR A PARTICULAR PURPOSE.

This product is designed, manufactured and marketed by :



**impro**<sup>®</sup>  
Technologies (Pty) Ltd  
Reg. No. 90/06574/07





(website)  
[http:// www.impro.net](http://www.impro.net)



 47 Gillitts Road  
Pinetown  
South Africa 3610

 P O Box 15407  
ASHWOOD  
South Africa 3608

 (031) 27 31 700-1087

 (031) 27 31 700-1511

 (e-mail)  
[impro@impro.net](mailto:impro@impro.net)



 424 Skinner Blvd, Suite A  
Dunedin, FL 34698  
USA

 (727) 733 7061

 (727) 736 1031

 Toll Free Number (US & Can):  
1 800 390 5837

 (e-mail)  
[support@impro.us.com](mailto:support@impro.us.com)

## CONTENTS

INTRODUCTION.....	4
IMPROX IR TRANSMITTER SPECIFICATIONS .....	4
PHYSICAL SPECIFICATIONS.....	4
ENVIRONMENTAL SPECIFICATIONS .....	5
ELECTRICAL SPECIFICATIONS .....	5
INSTALLATION GUIDE.....	5
LOCATION AND ORIENTATION .....	5
Mounting .....	6
Connecting the Power Supply.....	6
Related Products .....	7
Associated Access Control Systems.....	7
APPLICABILITY OF THIS MANUAL .....	8

### Figures

Figure 1 : Vehicle Infrared Transmitter; side view .....	5
Figure 2 : Transmitter installation and orientation; top view.....	5
Figure 3 : Connections.....	6

## INTRODUCTION

This Impro unit uses Infrared communication as it is relatively free from interference from vehicle electric/electronic and industrial noise. The transmitted low power infrared beam is limited in distance and therefore the likelihood of interference to other systems is virtually nil. Because of its inherent characteristics it requires no adjustment or tuning.

The ImproX Infrared Vehicle Transmitter is intended for use with the ImproX IR Infrared Receiver in vehicle automatic access control applications, where detection at medium range is required (approximately 6 m). The transmitter ID codes, pre-programmed during manufacture, follow the format of ImproX tag codes. These are entered into the Access Control system software, and are used to validate entry and exit by gate control.

Tag IDs can be entered into IPX 200 and 300/400 Systems which have an IR compatible ProxPal reader, or ProxMate reader. The codes are automatically entered and validated via the reader.

The VT Transmitter is intended to be installed in a vehicle and mounted internally on the windscreen. Power is supplied from the vehicle's battery via the ignition switch.

The VT Transmitter continuously radiates the Tag Identity code. This signal is received by the IR Receiver as soon as the vehicle comes into range. This code is then used by the Access Control System to identify the vehicle and provide entry or exit control by opening a gate or lifting a boom.

## APPLICATIONS

- Vehicle Access Control systems.
- Vehicle Identification systems.

## FEATURES

- Small physical size.
- Operates from vehicle battery.
- Low current consumption.
- High immunity to electrical noise.
- Internally mounted in the vehicle.
- Hands-free, automatic operation.
- Coded tag format identity code.
- Compatible with ImproX IR Receiver.

## IMPROX VT TRANSMITTER SPECIFICATIONS

### PHYSICAL SPECIFICATIONS

<b>Dimensions</b>	:	L = 40,5 mm (1,59"), W = 42.7 mm (1,68"), H = 40,5 mm (1,59") including pillar.
<b>Mass</b>	:	14 grams (0,5 oz).

<b>Material</b>	: Molded heat resistant, high impact Polycarbonate housing. GRP PCB.
<b>Colour</b>	: Dark Red.

## ENVIRONMENTAL SPECIFICATIONS

<b>Temperature, operating</b>	: -15 °C to +50 °C (+5 °F to +122 °F).
<b>Temperature, storage</b>	: -20 °C to +70 °C (-4 °F to +158 °F).

## ELECTRICAL SPECIFICATIONS

### Power Requirements

<b>Voltage</b>	: 6 V to 15 V DC.
<b>Current (mA)</b>	: 100 (max) @ 12 V DC supply voltage.

### IR Wavelength

: 940 nm.

### Identity Code

: Pre-programmed during manufacture and printed on the connecting cable surround sleeve.

### Read Range

: 6 m (nominal) from the Receiver.

## INSTALLATION GUIDE

Install the Infrared Vehicle Transmitter onto the vehicle as detailed below.

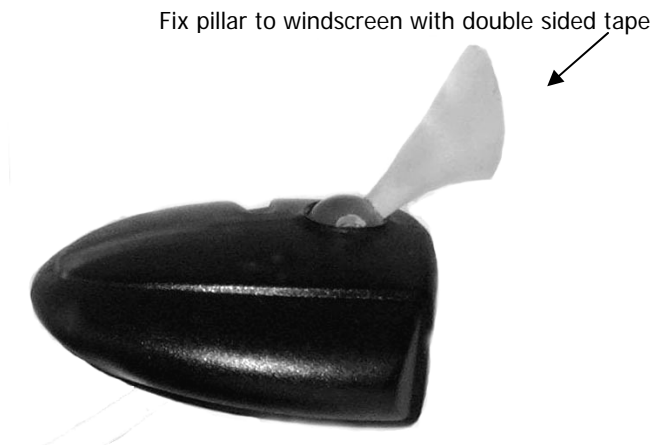

**Figure 1 : Vehicle Infrared Transmitter; side view.**

## LOCATION AND ORIENTATION

The transmitter must be mounted internally on the vehicle windscreen. It is possible to mount it elsewhere, but be aware that the transmitter/receiver focusing alignment must be positioned in relation to each other. The transmitter is **not** weatherproof. The orientation of the transmitter is important, and the length axis of the transmitter must "point" towards the receiver as shown in Figures 1 and 2. The broader face is the transmitter output.

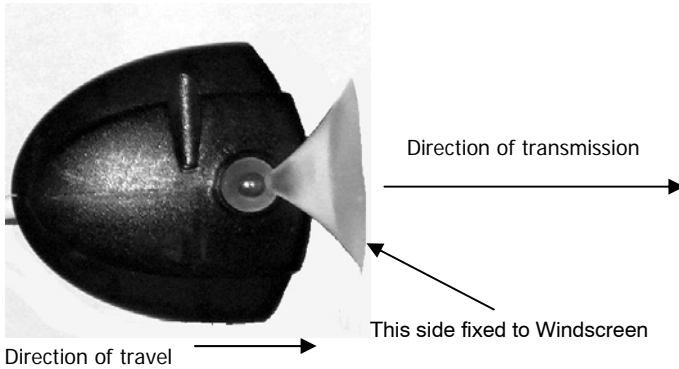

**Figure 2 : Transmitter installation and orientation; top view**

### Mounting

Mount the unit with the pillar stuck onto the windscreen (lower right or left pillar) using the supplied double-sided tape. Ensure that the Transmitter is not too close to the side edge of the windscreen, and thus pointing sideways, but also not in line with the driver's view. The location of the unit should be on the same side that the Receiver expects the gate. The location of the unit should be on the same side that the Receiver is mounted and be angled to point directly in the direction that the Receiver expects when the vehicle is approaching the gate.

### Connecting the Power Supply

The IR Transmitter requires a voltage between 6 V and 15 V DC.

- [1] Connect the blue lead to the vehicle negative supply [or chassis, if more convenient, for a negative chassis system].
- [2] Connect the red lead to the vehicle ignition supply (+ve) from the ignition switch distribution connection. This ensures that as soon as the vehicle ignition is switched on the Transmitter is likewise switched on and will be transmitting.

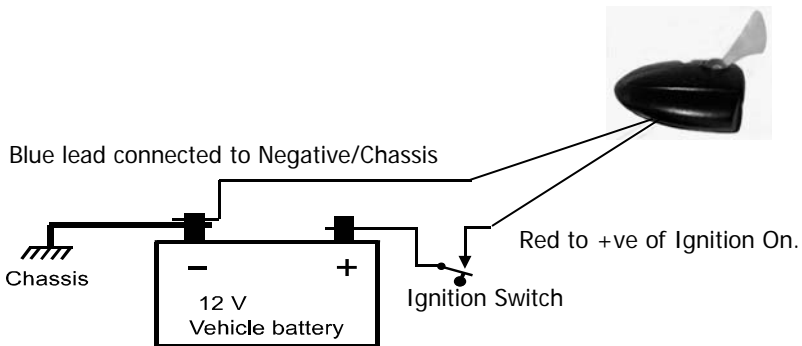

**Figure 3. Connections**

**NOTE :** *In the case of a vehicle with positive earth system, reverse the connections.*

## **RELATED PRODUCTS**

ImproX Infrared Receiver, with the Improx DT or PT, and an Impro IXP 200 or IXP 300/400 Access Control System.

## **ASSOCIATED ACCESS CONTROL SYSTEMS**

For details of associated Impro Access Control Systems such as the IPX 100, IPX 200 and IPX 300/400, please consult your Impro Technologies distributor.

## **USER'S NOTES**

## USER'S NOTES

### APPLICABILITY OF THIS MANUAL

The last two digits of the standard Impro stock code indicate the issue status of the item concerned. This manual is applicable to the Improx IR Infrared Transmitter stock code IVT-900-0-1-GB-00 onwards. The next issue of this manual will determine the final equipment issue to which this issue is applicable.

*Please advise us of any errors or omissions in this manual to enable us to improve our service to you.*

Thank you for choosing *Impro* products to implement your security or asset management systems.

*Impro Technologies* design and manufacture a wide range of technically advanced, high-quality, reliable Access Control and Asset Identification and Management Systems. Please contact your distributor to find out more about our products, or advise us of your needs for specialised products not yet in our extensive and continually expanding range.

PATENTS AND REGISTRATIONS FOR IMPROX DESIGNS HAVE BEEN GRANTED OR ARE PENDING (WORLD-WIDE). REGISTRATION OF THE TRADEMARKS 'ImproX' AND 'ImproNet' HAVE BEEN GRANTED OR ARE PENDING (WORLD-WIDE).

IVT-300-0-0-GB-00

Issue 1

January 2002

k:\Custman\ ImproX IR\ English Manuals\  
improx-vt\_transmitter-insm-en-01.doc