



IMPROX iTAR

ImproX (iTAR) Industrial Time Attendance Remote Reader INSTALLATION MANUAL

SPECIFICATIONS

Working Environment	The Remote Reader is designed to work in an indoor or outdoor environment, similar to IP55. The Remote Reader is, therefore, sealed against water.	
Input Voltage	5 V DC, polarity sensitive.	
Power Requirements	Current (mA)	Power (W)
Input Voltage 5 V DC, Indicators ON, Back-lighting ON.....	130	0.65
Buzzer		
Volume and Tone	Single tone, with a 4-step adjustable volume.	
Status Indicators		
Status LED	Bi-colour Red or Green LED (externally visible). The functions are application specific.	
Liquid Crystal Display (LCD)		
Characters	16 Characters by 1 line.	
Character Set.....	English, Katakana.	
Contrast	Software adjustable in 8 discrete steps via the Communications Protocol.	
Back-lighting.....	Permanently on.	
Keypad	4 Buttons, used for entering Reason Codes.	

INSTALLATION INFORMATION

Accessories

Find the following when unpacking the Remote Reader:

- An ImproX (iTAR) Industrial Time Attendance Remote Reader, supplied in a Light Grey Polycarbonate Plastic housing. The housing consists of a Lid and Base held together with six M4 x 20 mm, Pozi-drive screws.
- Two Plastic Cable Glands, PG7, 12.5 mm hole.

CAUTION: Use the TORX® Fasteners (M4 x 20 mm) as added security when attaching the enclosures Lid and Base.

- Three TORX® Fasteners (M4 x 20 mm).
- A T20 TORX® Key.
- An extra Serial Number Label.

General

Remember the following when installing the Remote Reader:

Maximum Data Communications Distance

The distance between the Remote Reader and the Terminal can be extended to a maximum of 10 m (33 ft) using a good quality shielded multi-strand 2-pair twisted cable. The individual conductor cross-sectional area of the cable must not be less than 0.2 mm² (0.0003 in²).

Distance between Remote Readers from DIFFERENT Terminals or Controllers

To avoid mutual interference, install the Remote Readers no closer than 500 mm (20 in) apart.

Mounting the Remote Reader

CAUTION: Make certain that you mount the Remote Reader on a vibration-free surface.

CAUTION: Use the TORX® Fasteners (M4 x 20 mm) as added security when attaching the enclosures Lid and Base.

Select the mounting position of the Remote Reader, considering accessibility, routing of wires and visibility of the externally visible LEDs and Liquid Crystal Display (LCD).

Secure the enclosure to the mounting surface, using four suitable screws and wall plugs, nuts and bolts or rivets.

Blank Space

Connecting the ImproX iTAR Remote Reader

Figure 1 to Figure 3 show detailed connection diagrams for the Remote Reader.

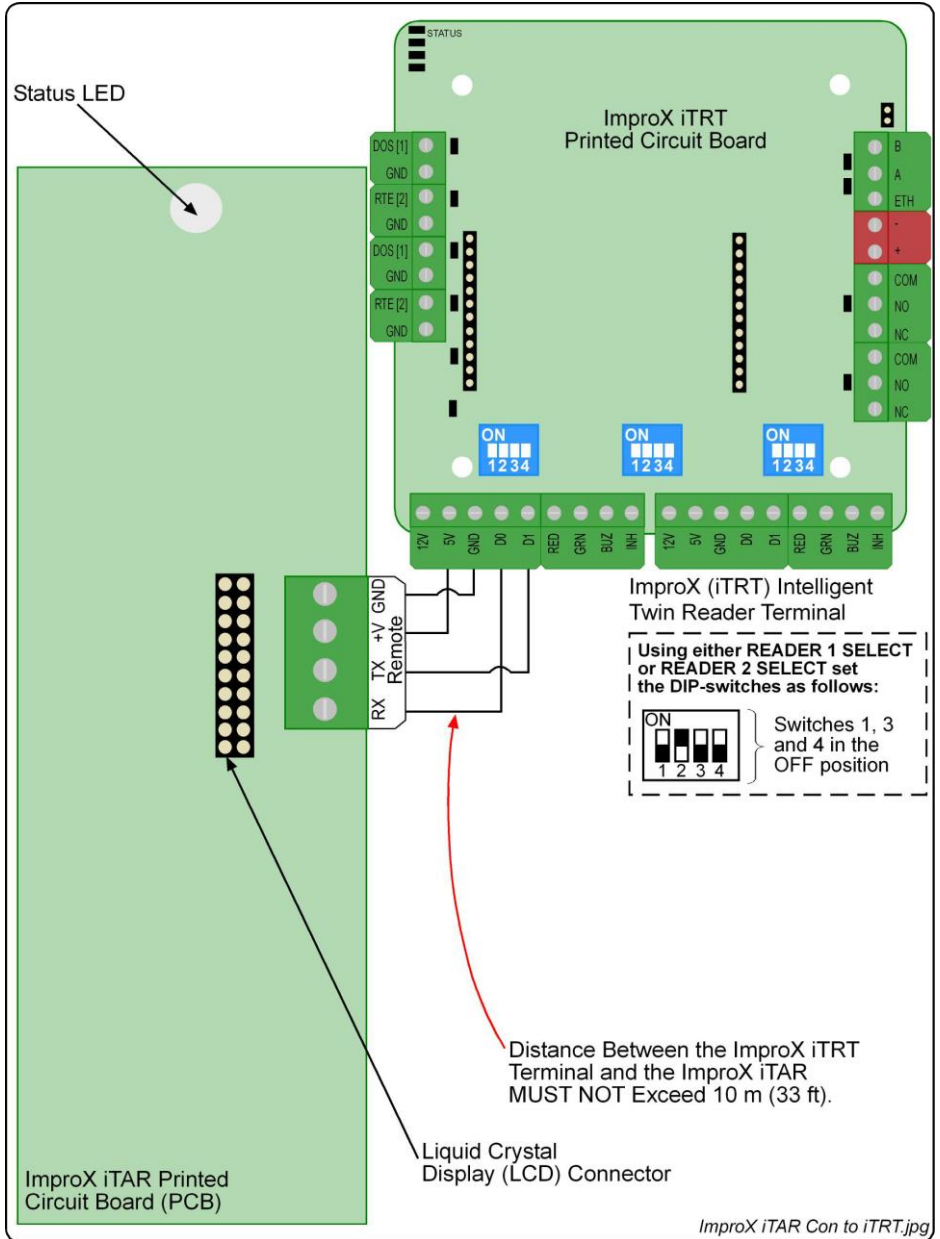

Figure 1: ImproX iTAR Connected to the ImproX iTRT Terminal

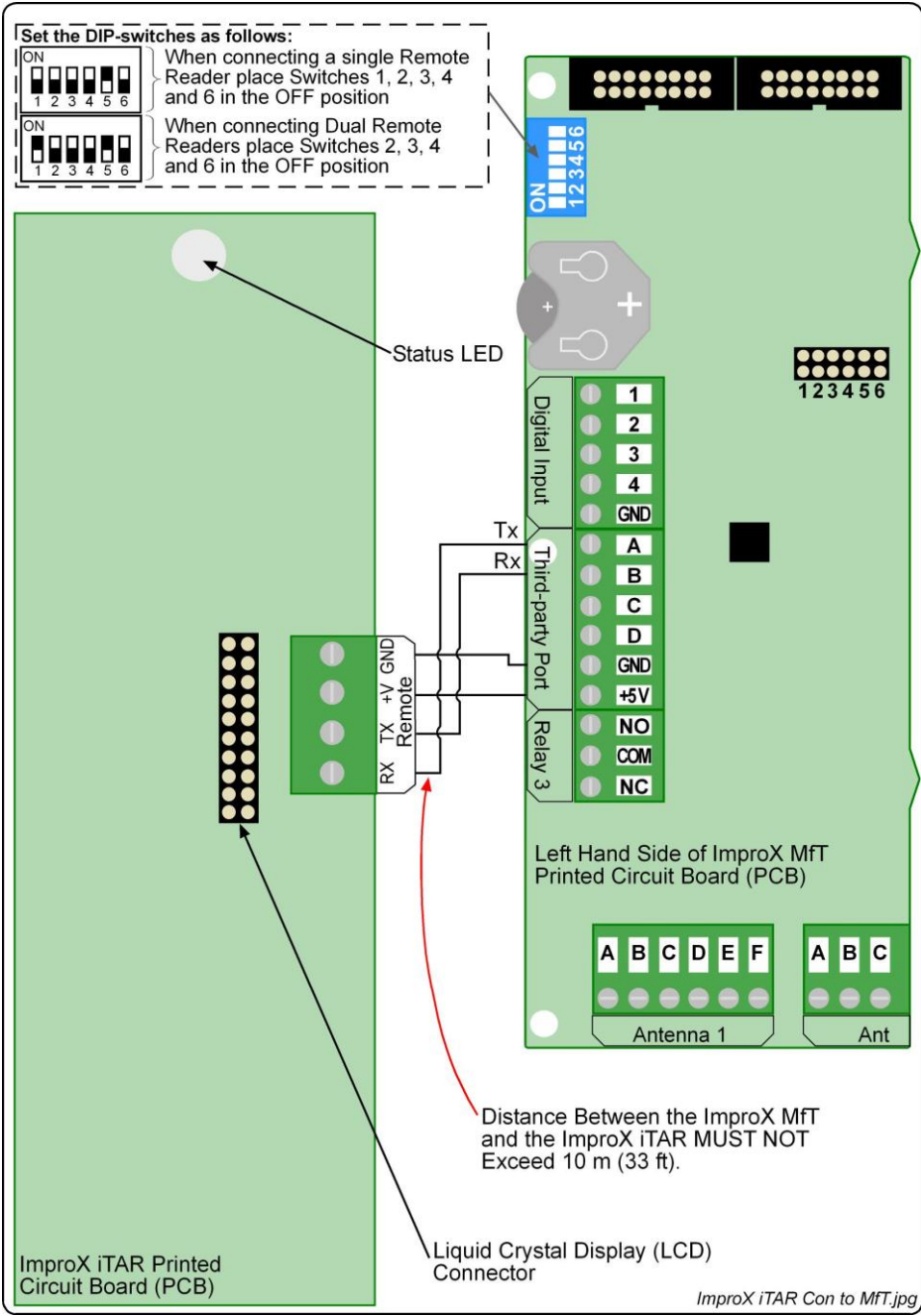

Figure 2: ImproX iTAR Connected to the ImproX Mft Terminal

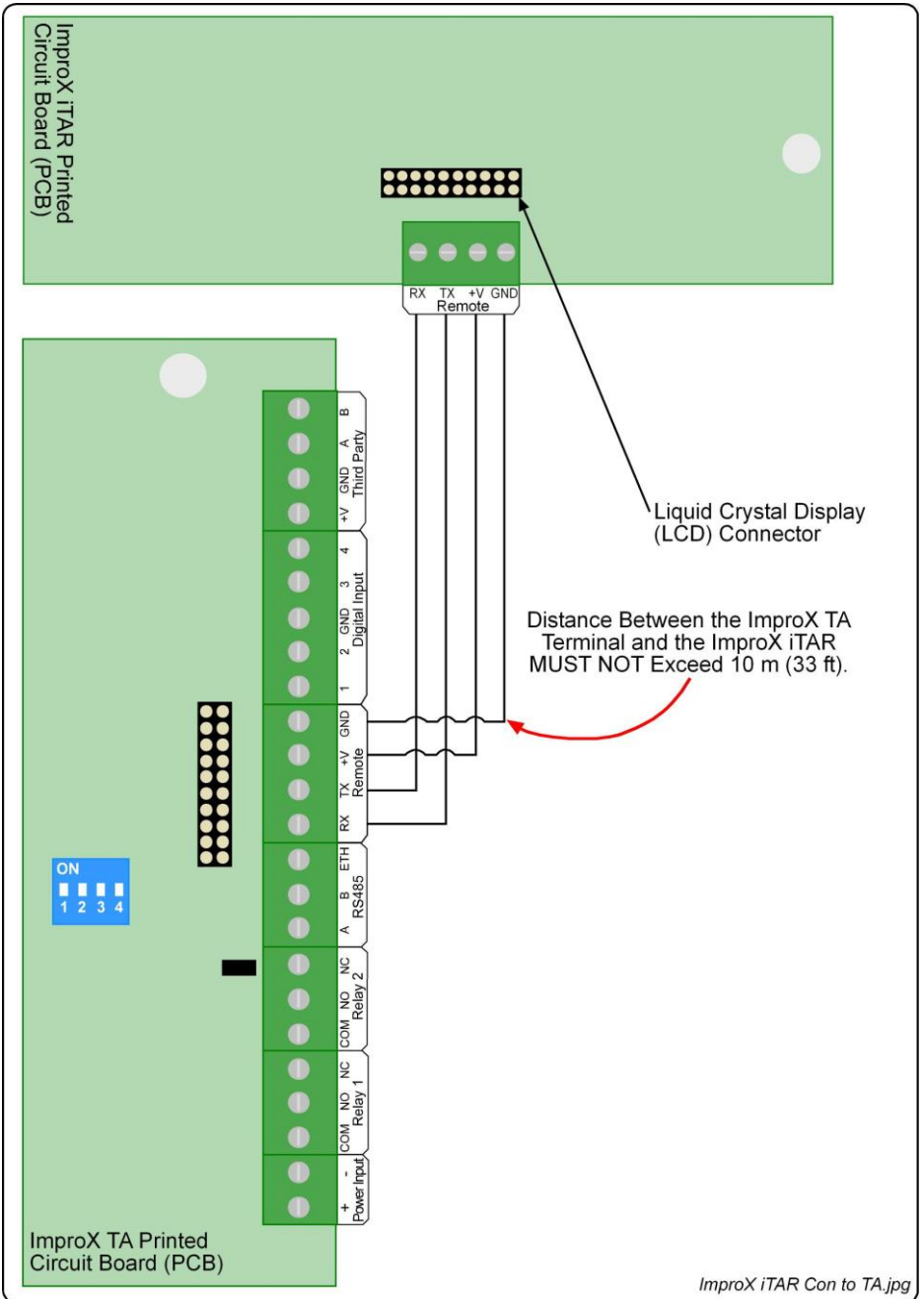

Figure 3: ImproX iTAR Connected to the ImproX TA Terminal

NOTE: *On powering up, the Remote Readers Status LED will illuminate solid Red, and the Buzzer will beep twice.*

The Remote Reader will not read Tags until configured in the Software. Details of these procedures are located in the IXP220 or ImproNet Software Manuals.

Serial Number Label

Once the Remote Reader is installed, sketch a rough site plan. The loose Serial Number Label (packaged with the Remote Reader) should be used (paired) in conjunction with the ImproX iTRT, ImproX MfT or ImproX TA Terminal Fixed Address Label.

The Remote Reader does not have its own Fixed Address. When connected to an ImproX iTRT, ImproX MfT or ImproX TA Terminal it is assigned one of the available Fixed Addresses.

The Serial Number Label identifies the type of Remote Reader, and the Fixed Address Label (shipped with the ImproX iTRT, ImproX MfT or ImproX TA Terminal) identifies the Fixed Addresses. Both these labels should be attached to the site plan to assist in identifying the hardware once an Auto-ID is performed.

GUARANTEE OR WARRANTY

This product conforms to our Guarantee or Warranty details placed on our Web Site, to read further please go to www.impro.net.

USER NOTES

USER NOTES

USER NOTES

This manual is applicable to the ImproX (iTAR) Industrial Time Attendance Remote Reader, XTA907-1-0-GB-00. (The last two digits of the Impro stock code indicate the issue status of the product).

XTA305-0-0-GB-03	Issue 04	Aug 2011	ImproX iTAR\English Manuals\LATEST ISSUE\iTAR-inism-en-04.docx
------------------	----------	-------------	---